

TF428WNM/U

Communicating Fan Coil Thermostat

SPECIFICATION DATA



General

The TF428WNM/U communicating thermostat is designed for 3-speed fan and valve control in a fan coil system, including:

- 2-pipe cool only/heat only/manual changeover
- 4-pipe cool /heat manual / automatic changeover
- Ventilation mode
- Manual or automatic 3-speed fan control
- Water valve on/off control

The TF428WNM/U is available in Modbus RTU protocol and can be easily integrated into building automation system.

Features

- **RS485 interface in Modbus RTU slave mode**
- **Memorized time off**
- **Cycle Per Hour (CPH)**
- **Random startup**
- **LCD display with simple user interface**
- **Room temperature or setpoint temperature display selectable**
- **Manual or automatic fan speed selectable**
- **Temperature units in either °C or °F**
- **User setting can be stored when power loss**
- **Freeze protection function available**
- **Keypad lock options**

Specifications

Physical Layer	EIA485
Protocol	Modbus RTU
Baud rate	4800/9600(Default)/19200
Parity	None
Error Checking Mechanism	CRC
Rated Power & Frequency	220/230VAC, 50/60Hz
Power consumption	<2W
Control	PI, On/off output
Accuracy	±1°C at 21°C
Auto Cycle times	100,000 times
Manual Cycle times	10,000 times
Protection class	IP20
Set point range	10 ~ 32°C
Display range	0 ~ 37°C
Ambient operating limits	0~ +49°C
Ambient storage limits	-30 ~ +60°C
Humidity limits	5~90% RH, non-condensing
Action Type:	1
Pollution Degree	2
Protection against electric shock class	Class II
Electronic control software class	Class A
Rated Impulse Voltage:	2500V
Maximum Temperature for	155°C
Relay wiring	
Wire Sectional area	
(Recommendation)	1.0~1.5mm ²
Applied altitude up to	2000m above sea level
Rating Capacity	
Working current for the whole product :	4(3)A
4A: When the load of the thermostat is resistance	
3A: When the load of the thermostat is inductance	
For Fan load 3(2)A	
3A:when the load is resistance; 2A:When the load is inductance	
For Valve load 2(1)A	
2A: when the load is resistance;1A: when the load is inductance	
The valve need have overtravel-limit organ to turn off the load.	

Model Selection

Model Number	Backlight	Application	Power Supply	Ventilation Mode	Energy Saving Mode
TF428WNM/U	White	2/4 pipe FCU	220/230Vac; 50/60Hz	Y	Y

Product Design

Thermostat appearance



Dimensions (mm)

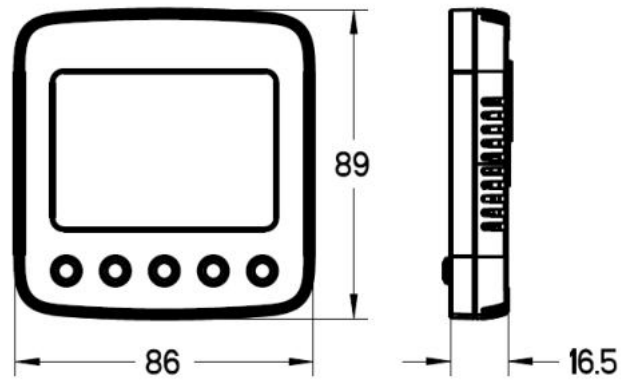

LCD display

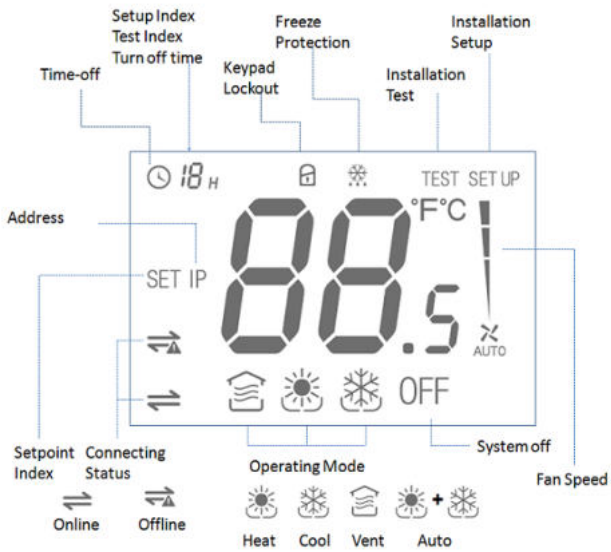

Function

Valve Control

Thermostat measures the room temperature via integrated sensor and maintains the setpoint by delivering on/off valve control command outputs.

The fan setting can be selected as manual or automatic 3-speed operation. When in “manual” mode, the fan is switched to the selected speed via control output FH (high), FM (Medium) , FL (Low).

While in “automatic” mode, fan speed depends on the difference between room temperature and setpoint. When room temperature reaches the setpoint, the valve will be closed, and the fan will be closed in the meanwhile.

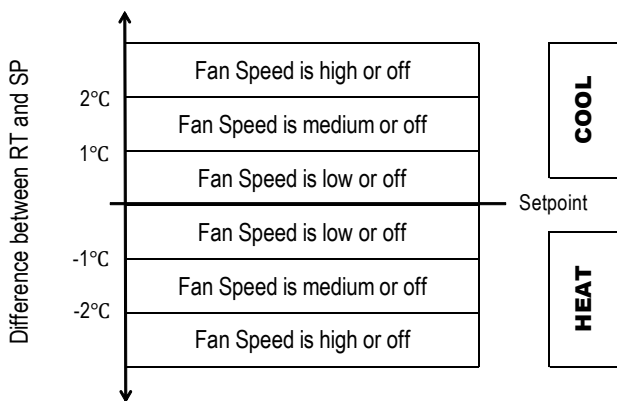

Fig. 1. Fan Speed Ramping Control Algorithm

Memorized Time Off

The time off feature will automatically turn off the thermostat after a selectable amount of time. To change the time setting, press and hold the power button for more than 3 seconds and press “up” and “down” button to change the value when the thermostat is working .

NOTE: The setting range is from 0 to 12 hours. The step is 1 hour and the default value is 0.



Backlight

To turn on the backlight, press any key. The backlight will timeout 8 seconds after the last key is pressed. When in ISU and Installation test mode, the backlight will timeout 60 seconds after the last key is pressed.

Keypad Lockout

Keypad lockout can be set in ISU or over Modbus. The default status is “all keys available”. Keypad lock can be optioned to “mode button locked”, “Fan and mode buttons locked”, “all buttons (except power button) locked” and “all buttons locked”.

Temperature Display

The displayed temperature can be set to room temperature or setpoint. The setting can be changed during ISU (Installation Set Up) process.

Cycle Per Hour (CPH)

CPH function enables the thermostat to open the valve several times per hour as the room temperature gets close to the setpoint.

The value can be changed in the ISU, the default values are 4 for heating and 3 for cooling.

Operating Mode

Comfort Mode

In comfort mode, the setpoint and fan speed can be changed by pressing corresponding buttons. Comfort mode including 2-pipe cool only/heat only/manual changeover and 4-pipe manual /auto changeover applications.



Energy Saving Mode

Energy saving mode can be activated over Modbus.

If energy saving mode is activated over Modbus, then all keys will be locked to prevent the individual control on site. When disable the energy saving mode over Modbus, all keys will be available.

The setpoint will change to the energy saving heating/cooling setpoint when the energy saving mode is enabled.

Ventilation Mode

Press “mode” button to enter “ventilation” mode. In “ventilation” mode, no output for valve while the fan will operate at selected fan speed.



Freeze Protection Mode

Freeze protection can be selected as disabled or enabled (default) in the ISU or over Modbus. In freeze protection mode (only in heating applications), when thermostat is off and the temperature is below 6°C, the thermostat will activate heating mode until the temperature rises to 8°C.



Installation and Wiring

TF428WNM/U can be installed in standard 86 size junction box directly.



The screws must be locked tightly to avoid wire break off from the terminals.
The temperature of mounting box and wall should be in the operating temperature range.

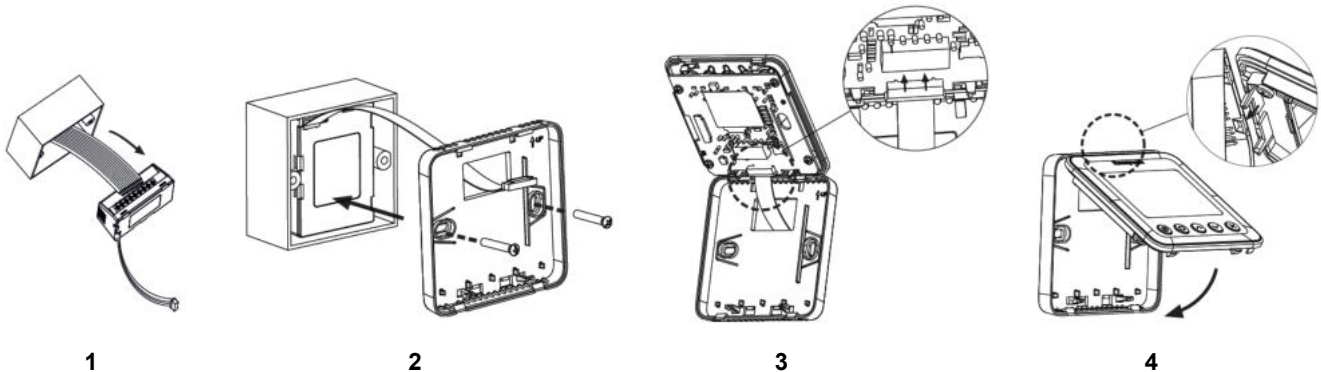

Wiring Diagram

2 pipes application

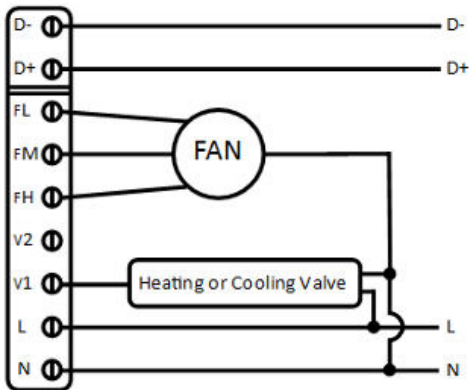

Fig. 2. Honeywell VC4013/VN4013/VS4016 Wiring

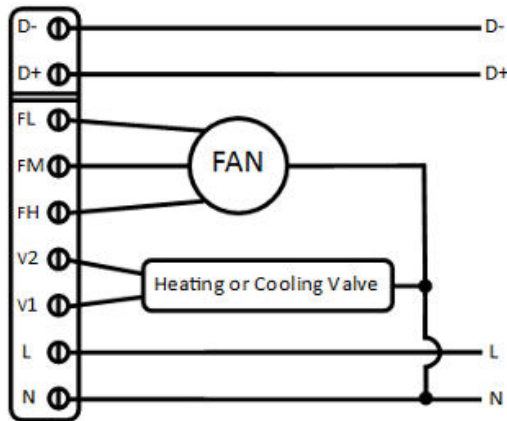

Fig. 3. Honeywell VC6013/VN6013 Wiring

4 pipe application

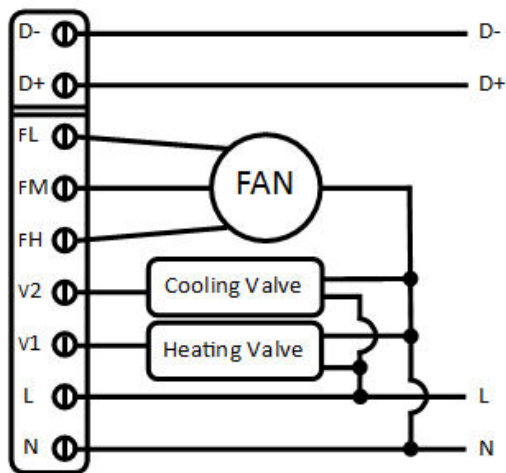

Fig. 4. Honeywell VC4013/VN4013/VS4016 Wiring

Terminal Designations

Item	Terminal	Description
1	D-	Modbus 485-
2	D+	Modbus 485+
3	FL	Low speed fan
4	FM	Medium speed fan
5	FH	High speed fan
6	V2	2 pipe_VC6013 Valve close 4 pipe_VC4013 Cooling valve open
7	V1	2 pipe_VC4013/VC6013: valve open 4 pipe_VC4013 Heating valve open
8	L	Live wire
9	N	Neutral wire

ISU (Installation Setup)

Press and hold the “mode” and “up” buttons together for more than 3 seconds to enter or exit ISU. Change the ISU code by pressing the “mode” button and then change the option setting by pressing the “up” and “down” button refer to the following introduction.

ISU Code	Description	Options
0	Modbus Address	1~64 1(Default)
1	System Type	0 Heat only
		1 Cool only
		2 Two pipes heating/cooling manual (Default)
		4 four pipes manual
		5 four pipes auto
2	Temp. Scale	0 °F
		1 °C (Default)
3	Fan control Type	0 Auto only
		1 manual only (3 speed: Low→Med→High→Low)
		2 users can choose auto or manual (Default)
4	Switching differential for 4 pipe auto changeover with single setpoint	1°C (2°F)
		1.5°C (3°F)(Default)
		2°C (4°F)
		3°C (5°F)
5	CPH (Heat)	1~12 4(Default)
6	CPH (Cool)	1~6 3(Default)
7	Display Temp. adjustment	-2~2°C, 0.5°C. Default 0°C (-4~4°F, 1°F. Default 0°F)
8	Temp. Display	0 room temp. (Default)
		1 set point
9	Heating Range Stops	10~32°C. Default 32°C (50~90°F. Default 90°F)
10	Cooling Range stops	10~32°C Default 10°C (50~90°F. Default 50°F)

ISU Code	Description	Options
11	Keypad lockout	0 All keys are available (Default)
		1 mode button locked out
		2 Fan and mode button locked out
		3 All button locked out except power button
13	Freeze Protection	4 All button are locked
		0 Disabled
14	Power Recovery status	1 Enabled (Default)
		0 OFF
15	Fan mode in ES Mode	1 Previous status (Default)
		0 Run as Auto when ISU_3=2 (Default)
16	Modbus Baud rate	1 Run as low when ISU_3=2
		0 9600(Default)
		1 4800
		2 19200

Communicating Parameter Setting

When the thermostat is integrated into building automation system. Please make configuration refer below list.

Address Registers	Configuration parameters	Significance and adjustment	Properties
01	Power Switch	0-Off;1-On	R/W
02	Room Temperature	Room Temperature value	R
03	Temp. Scale	0-°F; 1-°C	R/W
04	Setpoint	Set temperature value	R/W
05	Fan Mode	0-Auto 1-Low speed; 2-Med speed; 3-High speed;	R/W
06	System Mode	0-Ventilation; 1-Heat; 2-Cool 3-Auto	R/W
07	Heat Valve status	0-closed;1-open	R
08	Cool valve status	0-closed;1-open	R
09	Error Code	0-None; 1-Sensor 2-EEprom; 3-Sensor+EEprom	R
10	Energy Saving Mode	0-Disable; 1-Enable	R/W
11	Modbus Address	1~64 1(Default)	R/W
12	System Type	0-Heat only;1-cool only; 2-Two pipes heating/cooling manual (Default) 4-four pipes manual;5-four pipes auto	R/W
13	Fan Control Type	0-Auto; 1-Manual; 2-Auto+Manual (Default)	R/W
14	Switching differential for 4 pipe auto changeover with single setpoint	1-3°C step 0.5°C 1.5°C (Default) 2-5 °F step 1°F 3°F(Default)	R/W
15	CPH (Heat)	1-12 4(Default)	R/W
16	CPH (Cool)	1-6 3(Default)	R/W
17	Display Temp. adjustment	0~8(-2~2°C) step 1(0.5°C) 4(Default) 0~8(-4~4°F) step 1 (1°F) 4 (Default)	R/W
18	Temp. Display	0- room temp. (Default) ;1-set point	R/W
19	Heating Range Stops	100~320 (10~32°C) step5(0.5°C) 320(Default) 500~900 (50~90°F)step10(1°F) 900(Default)	R/W
20	Cooling Range stops	100~320 (10~32°C) step5(0.5°C) 100 (Default) 500~900 (50~90°F)step10(1°F) 500(Default)	R/W

Address Registers	Configuration parameters	Significance and adjustment	Properties
21	Keypad lockout	0- All keys are available (Default) ;1- system button locked out;2- Fan and system button locked out;3- All button locked out except power button;4- All button are locked	R/W
22	Energy Saving Heating Setpoint	10~21°C. Default 18°C (50~70°F. Default 64°F)	R/W
23	Energy Saving Cooling Setpoint	22~32°C. Default 26°C (72~90°F. Default 79°F)	R/W
24	Freeze Protection	0 Disabled 1 Enabled (Default)	R/W
25	Power Recovery status	0 OFF 1 Previous Status	R/W
26	Fan mode in ES Mode	0 Run as Auto when ISU_3=2 (Default) 1 Run as low when ISU_3=2	R/W
27	Modbus Baud rate	0-9600,1-4800,2-19200	R/W
28	Fan Status	0 –Off 1-Low 2-Mid 3-High	R/W
29	Time Off Time	0~12 Step 1 Unit :h	R/W
30	Remain time to turn off	Remain time to turn off	R

Honeywell

Automation and Control Solutions

Honeywell Environmental and Combustion Controls (Tian Jin) Co., Ltd
No. 158, NanHai Road
Tianjin Economic-Technological Development Area
Tianjin, 300457, P.R.C.

Subject to change without notice.