

DC1000 SERIES
DIGITAL CONTROLLER
PRODUCT MANUAL

51-52-25-113
Issue1
March 2004

Copyright, Notices, and Trademarks

Printed in Taiwan - © Copyright 2004 Honeywell International Inc.

Issue 1 - March 2004

Warranty / Remedy

Honeywell warrants goods of its manufacture as being free to defective materials and faulty workmanship. Contact your local sales office for warranty information. If warranted goods are returned to Honeywell during the period of coverage, Honeywell will repair or replace without charge those items it finds defective. The foregoing is Buyer's sole remedy and is **in lieu of all other warranties, expressed or implied, including those of merchantability and fitness for a particular purpose**. Specifications may change without notice. The information we supply is believed to be accurate and reliable as of this printing. However, we assume no responsibility for its use.

While we provide application assistance personally, through our literature and the Honeywell web site, it is up to the customer to determine the suitability of the product in the application.

© Copyright 2004 Honeywell International Inc.

Sales and Service

Honeywell serves its customers through a worldwide network of sales offices and distributors. For application assistance, current specifications, pricing, or name of the nearest Authorized Distributor, contact your local sales office. See back page

Industrial Measurement and Control

Honeywell Korea

191 HanGangRo 2ga, YongSanGu

Seoul, Korea

Contacts

World Wide Web

The following lists Honeywell's World Wide Web sites that will be of interest to our customers

<i>Corporate</i>	http://content.honeywell.com/
<i>Automation & Control Solutions</i>	http://www.acs.honeywell.com/ichome/Rooms/DisplayPages/LayoutInitial
<i>Industrial Measurement & Control</i>	http://content.honeywell.com/imc/



Telephone

Contact us by telephone at the numbers listed below

<i>United States and Canada</i>	<i>1-800-423-9883</i>	<i>Technical. Support</i>
	<i>1-888-423-9883</i>	<i>Q&A Faxback (TACFACS)</i>
	<i>1-800-525-7439</i>	<i>Service</i>
<i>Asia Pacific</i>	<i>+ (65) 6355 2828</i>	<i>Asia Pacific Headquarters</i>
<i>Europe</i>	<i>+ (32) 2 728 2111</i>	<i>Honeywell PACE, Brussels, Belgium</i>
<i>Latin America</i>	<i>+ (854) 845 2600</i>	<i>Honeywell, Sunrise, Florida U.S.A</i>

Symbol Definitions

The following advisory convention is used in this document to denote certain conditions.

Symbol	Definition
	<p>CAUTION</p> <p>This CAUTION symbol on the equipment refers the user to the Product Manual for additional information. In this manual, this symbol appears next to required information. Failure to comply with these instructions may result in product damage.</p>
	<p>WARNING</p> <p>PERSONAL INJURY: Risk of electrical shock. This symbol warns the user of the potential shock hazard where HAZARDOUS LIVE voltages greater than 30 Vrms, 42.4 Vpeak, or 60 Vdc may be accessible. Failure to comply with these instructions could result in death or serious injury.</p>

Contents

1. Overview	1
1.1 Introduction.....	1
2. Installation.....	2
2.1 Model Number Interpretation.....	2
2.2 Specification	3
2.3 Mounting.....	4
2.4 External Dimension	4
2.4.1 DC1010.....	4
2.4.2 DC1020.....	5
2.4.3 DC1030.....	5
2.4.4 DC1040.....	5
2.5 Wiring Diagrams	6
2.5.1 DC1010.....	7
2.5.2 DC1020.....	8
2.5.3 DC1030.....	9
2.5.4 DC1040.....	10
3. Configuration	11
3.1 Operator Interface	11
3.2 MODE Access	12
3.3 MODEs.....	13
3.3.1 Operation	13
3.3.2 Configuration 1	14
3.3.3 Configuration 2	15
3.4 Alarms	17
3.4.1 Deviation Alarm.....	17
3.4.2 Absolute Value Alarm.....	18
3.4.3 Program Alarm.....	19
3.4.4 System Alarm.....	19
3.5 Function Lock	20
4. Input Codes.....	21
4.1 Thermocouples.....	21
4.2 RTDs	22
4.3 Linear Inputs.....	22
5. Operation.....	23
5.1 Type of Control	23
5.1.1 Manual Operation	23
5.1.2 ON/OFF Control.....	23
5.1.3 PID Control	23
5.2 Set Point.....	23
5.3 Alarm Set Point	23
6. Error Message.....	24

1. Overview

1.1 Introduction

Function

The DC1000 family of microprocessor based controllers combine a high degree of functionality and reliability in 4 different formats: 1/16 DIN, 1/8 DIN, 3/16 DIN, and 1/4 DIN.

With a typical accuracy of $\pm 0.5\%$ of span, the DC1000 is an ideal controller for regulating temperature and other process variables in a variety of applications including dryers, semiconductor packaging & testing, plastic processing, packaging machinery, painting & coating, and climatic chambers.

Easy to Configure

Two different configuration levels provide easy access to parameters. A 4-digit security code prevents unauthorized changes. Parameters can also be hidden to the user to prevent improper configuration of the unit.

Various Control Algorithms

The DC1000 series of controllers provides several different algorithms:

- PID or ON/OFF Control
- Heat/Cool Algorithms with 2 different PID sets
- Motor Position Control without slidewire feedback
- Single Phase Control with/without zero crossover control
- Three Phase Control with/without zero crossover control

Mount Anywhere

The DC1000 family is industrial control equipments that must be panel mounted. The wiring terminals must be enclosed within the panel. The DC1000 is environmentally hardened and, when suitably enclosed, can be mounted virtually anywhere in plant or factory; on the wall, in a panel, or even on the process machine. It withstands ambient temperature up to 50°C (122°F).

CE Conformity (Europe)

This product is in conformity with the protection requirements of the following European Council Directive: **73/23/EEC**, the Low Voltage Directive, and **89/336/EEC**, the EMC Directive. Conformity of this product with any other "CE Mark" Directive(s) is not guaranteed.

Enclosure Rating: Panel-mounted equipment rating IP00. This controller must be panel mounted and all terminals must be enclosed within the panel. Front panel IP65 (IEC 529) option is available.

2. Installation



WARNING

Local Regulations regarding electrical & safety must be observed.

Failure to comply with these instructions could result in death or serious injury.

2.1 Model Number Interpretation

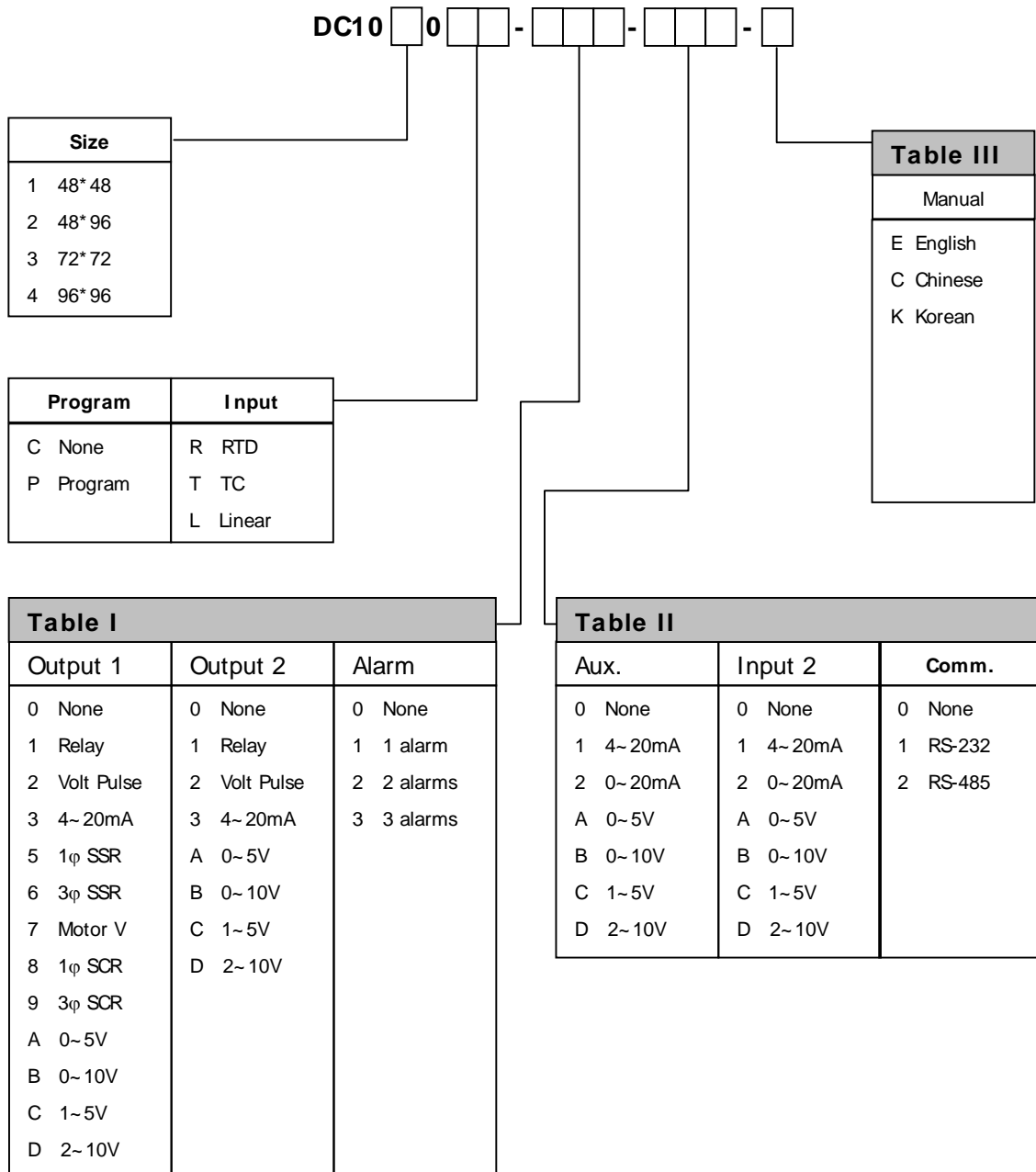

2.2 Specification

TECHNICAL DATA		
PV Input	Type of Input	TC (K, J, R, S, B, E, N, T, W, PL II, U, L), RTD (Pt100Ω, JPt100Ω, JPt50Ω) Linear (-10~10mV, 0~10mV, 0~20mV, 0~50mV, 10~50mV)
	Input Sampling Time	500 ms
	Input Resolution	14 bit (each)
Indication	PV/SP Indication	4-digit, 7 segment display
	Constant Value Storage System	Non-volatile memory (EEPROM)
Control Mode	Indication Accuracy	± 0.5%FS
	Proportional Band (P)	0~200% (On/Off action at P=0)
	Integral Time (I)	0~3600 sec (PD action at I=0)
	Derivative Time (D)	0~900 sec (PI action at D=0)
Output	Cycle Time	0~150 sec (4~20mA→0, SSR→1, relay→10)
	Relay Output	Contact, SPST(DC1010)/SPDT(1020,1030,1040), 3A/240VAC
	Voltage Output	Voltage Pulse, 20VDC/20mA
	Linear Output	4~20mA, 0~5V, 0~10V, 1~5V, 2~10V
	Motor Control Output	Three Position Step Control (Time proportional motor control)
Alarm	Others	1φ SSR, 3φ SSR, 1φ SCR, 3φ SCR
	Channel	3 channels (optional)
	Mode	17 alarm mode available
Aux. Output	Timer	Flicker alarm, continued alarm, on delay timer alarm
	Output Signal	SP, PV
	Type of Output	4~20mA, 0~20mA, 0~5V, 0~10V, 1~5V, 2~10V
2 nd Input (RSP)	Type of Input	4~20mA, 0~20mA, 0~5V, 0~10V, 1~5V, 2~10V
	Sampling Time	500 ms
Program	Pattern/Segment	2 pattern/ 8 segment (each)
	Availability	Pattern link & repeat, program/segment end alarm
Communication	Type of Communication	RS-232, RS-485
General Specifications	Rated Power Supply Voltage & Frequency	AC 90-240V, 50/60Hz or DC15-50V, 4VA
	Power Consumption	Max. 8VA
	Storage Temperature	-25°C~65°C
	Ambient Temperature	0°C~50°C
	Ambient Humidity	50~85% RH (no condensation)
INPUT ACTUATIONS		
TC	K	0.0~200.0, 400.0, 600.0, 800.0, 1000, 1200 °C
	J	0.0~200.0, 400.0, 600.0, 800.0, 1000, 1200 °C
	R	0.0~1600, 1769 °C
	S	0.0~1600, 1769 °C
	B	0.0~1820 °C
	E	0.0~800, 1000 °C
	N	0.0~1200,1300 °C
	T	0.0~400.0, 200.0 °C, 0.0~350.0 °C
	W	0.0~2000, 2320 °C
	PL II	0.0~1300, 1390 °C
	U	-199.9~600.0, 200.0 °C, 0.0~400.0 °C
RTD	L	0.0~400.0, 800.0 °C
	Pt100	-199.9~600.0, 400.0, 200.0 °C, 0.0~200.0, 400.0, 600.0 °C
	JPt100	-199.9~600.0, 400.0, 200.0 °C, 0.0~200.0, 400.0, 600.0 °C
Linear	JPt50	-199.9~600.0, 400.0, 200.0 °C, 0.0~200.0, 400.0, 600.0 °C
	AN1	-10~10mV
	AN2	0~10mV
	AN3	0~20mV
	AN4	0~50mV
AN5	10~50mV	4~20mA, 1~5V, 2~10V

2.3 Mounting



CAUTION

Installation Precautions

The controller can be mounted on either a vertical or tilted panel using the mounting bracket supplied. Adequate access space must be available at the back of the panel for installation and servicing activities.

Failure to comply with these instructions may result in product damage.

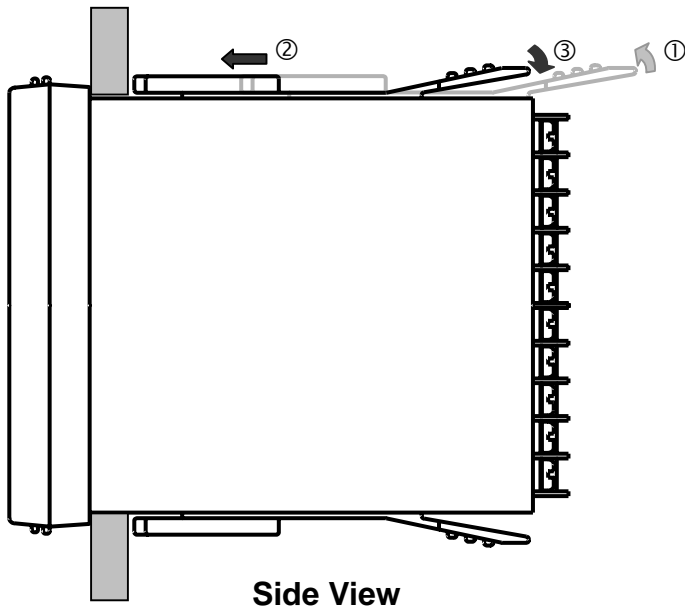

- 1 - Put the mounting bracket in the rail on the top & bottom of the case.
- 2 - Bend the grip of the bracket & slide the bracket along the rail until the case is secured against the panel.
- 3 - Put the grip of the bracket on the groove to fasten the case to the panel.

2.4 External Dimension

2.4.1 DC1010

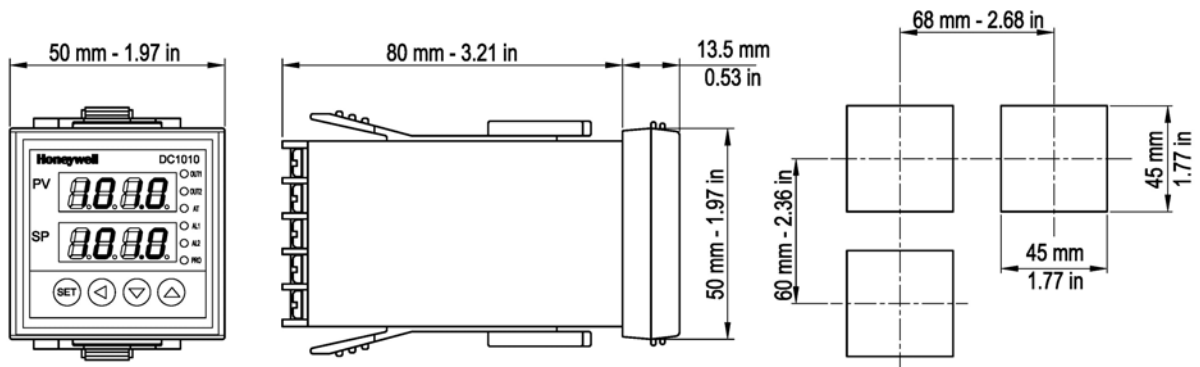

2.4.2 DC1020

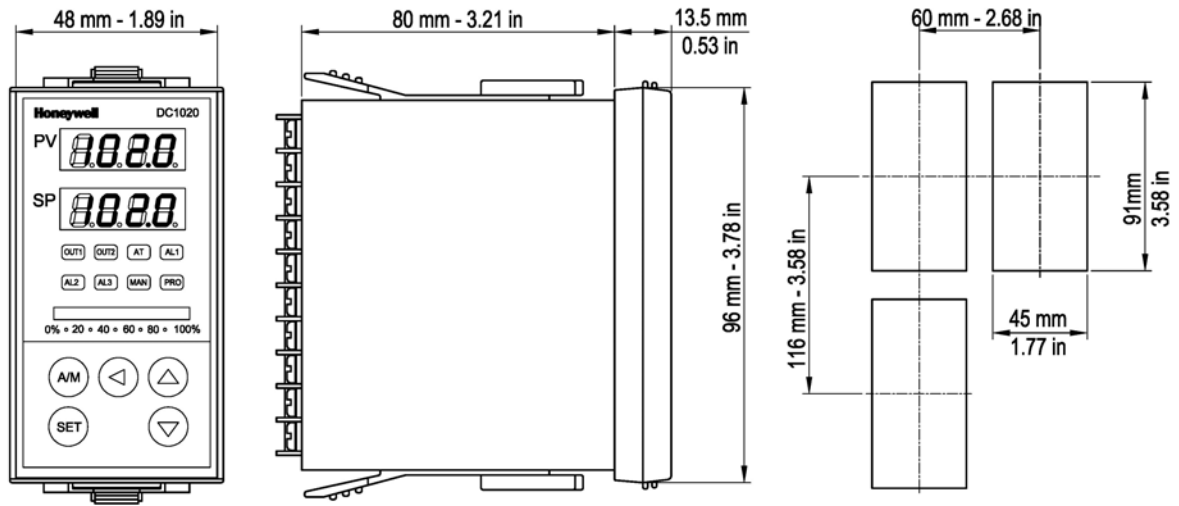

2.4.3 DC1030

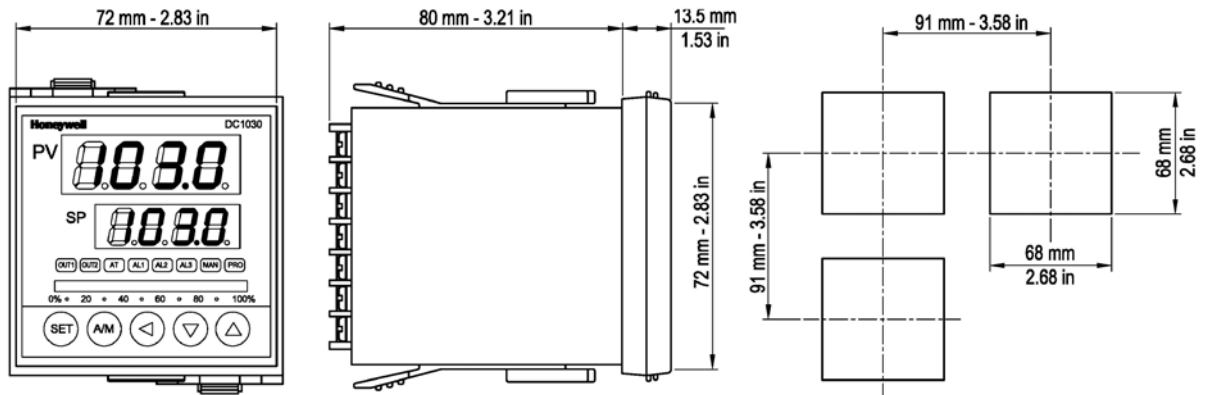

2.4.4 DC1040

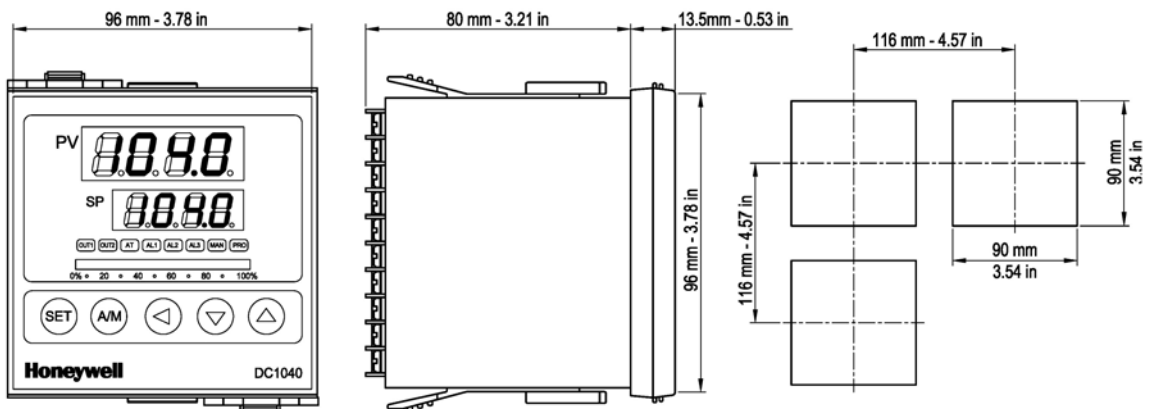

2.5 Wiring Diagrams



WARNING

Electrical Consideration / Precautions

The controller is considered “rack and panel mounted equipment” per EN61010-1, Safety Requirements for Electrical Equipment for Measurement, Control and Laboratory Use, Part 1: General Requirements. Conformity with 72/23/EEC Low Voltage Directive, requires the user to provide adequate protection against a shock hazard. The user shall install this controller in an enclosure that prevents OPERATOR access to the rear terminals.

Failure to comply with these instructions could result in death or serious injury.



CAUTION

Applying 85-264Vac to a controller rated for 15-50Vdc will severely damage the controller and is a fire and smoke hazard.

Failure to comply with these instructions may result in product damage.



CAUTION

Wiring Requirements

Shielded twisted pair cable is required for all Analog I/O, Process Variable, RTD, Thermocouple, dc millivolt, low level signal, mA, Digital Output, and computer interface circuits.

Failure to comply with these instructions may result in product damage.



CAUTION

Line Voltage Wiring

This controller is suitable for connection to 90-240 Vac, 50/60 Hz or 15-50 Vdc, power supply mains. It is the user responsibility to provide the following

- 90-240 Vac - a switch, fuse (1/2A, 250V) or a circuit breaker.
- 15-50 Vdc – a switch, fuse (1A, 125A) or a circuit breaker

Fuse types – North America non-time delay, Europe – Type F, quick acting fuse(s).

The above items should be installed together with DC1000 for the products electrical protection.

The switch or circuit-breaker should be located close to the controller, within easy reach of the operator. The switch or circuit-breaker should be marked as the disconnecting device for the controller.

When applying power to multiple instruments, make sure that sufficient current is supplied. Otherwise, the instruments may not start up normally due to the voltage drop caused by the in-rush current.

Failure to comply with these instructions may result in product damage.

2.5.1 DC1010

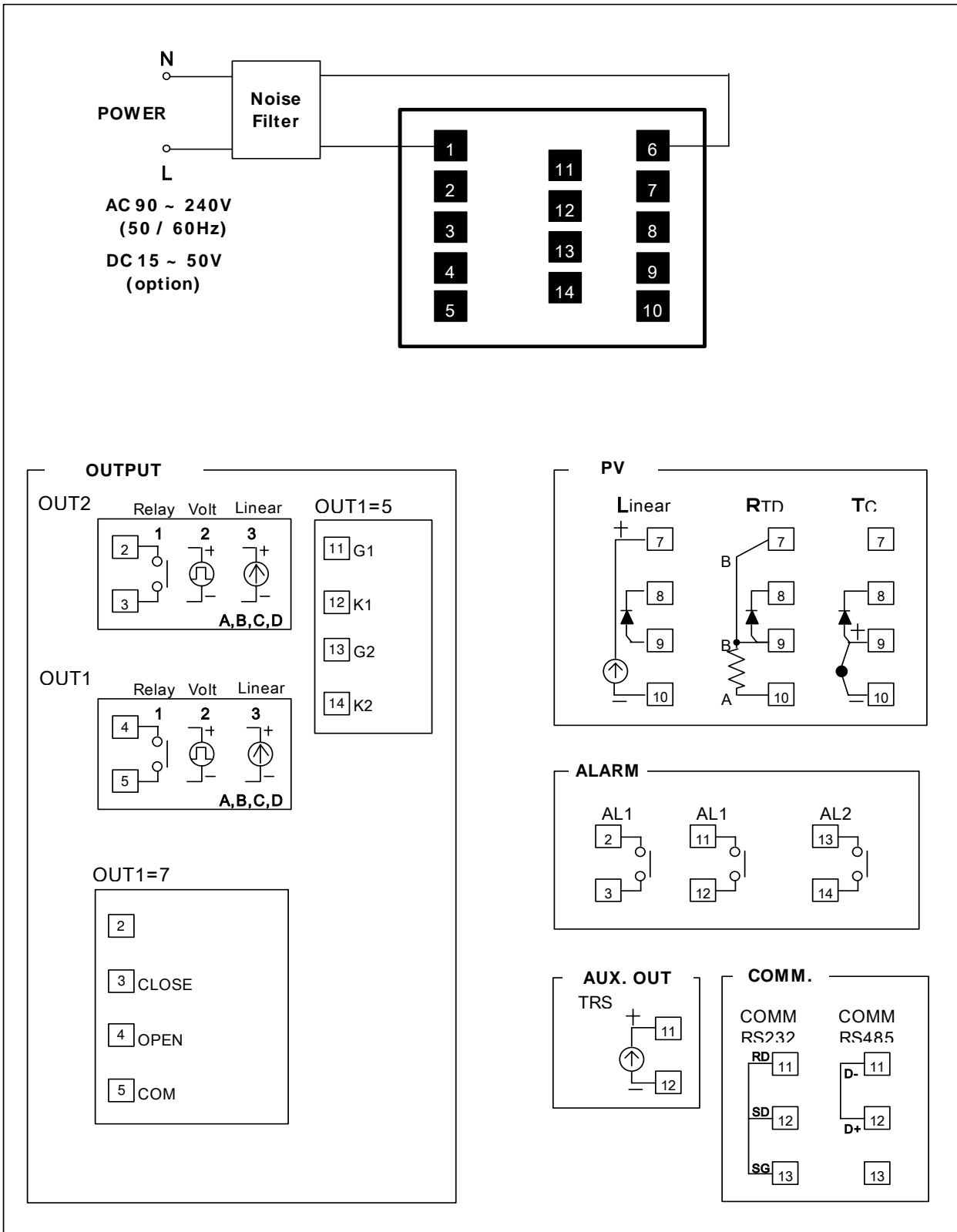

2.5.2 DC1020

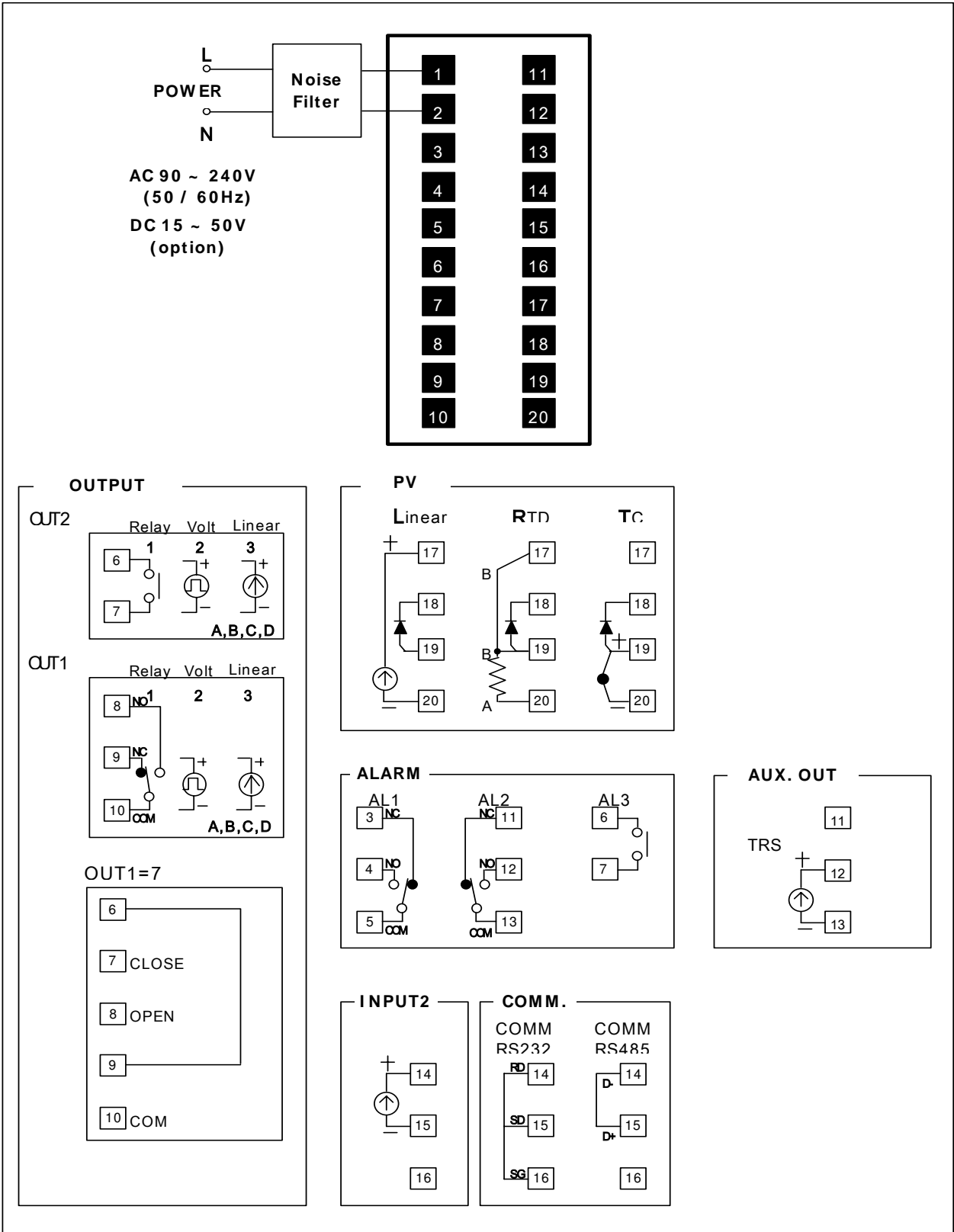

2.5.3 DC1030

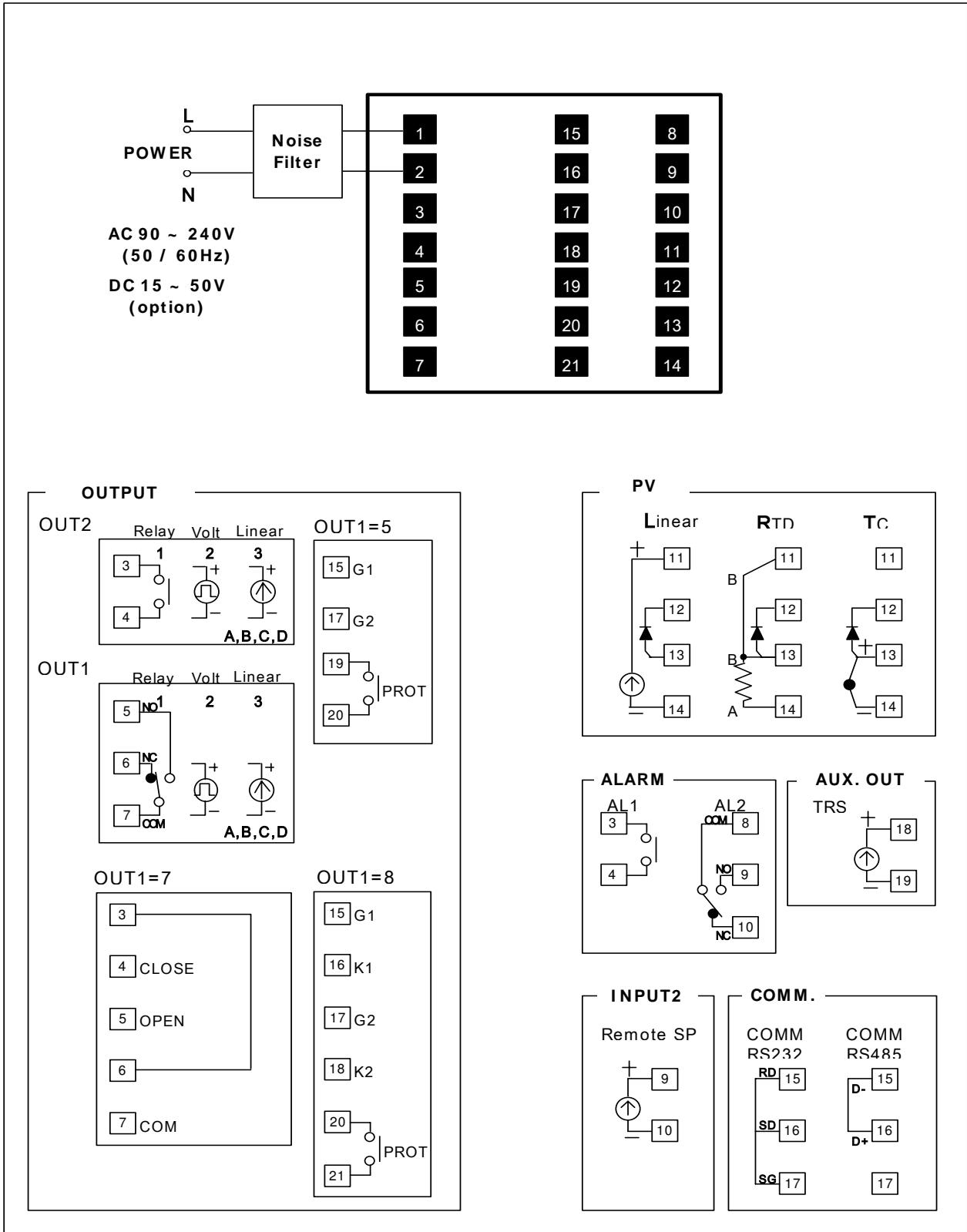

2.5.4 DC1040

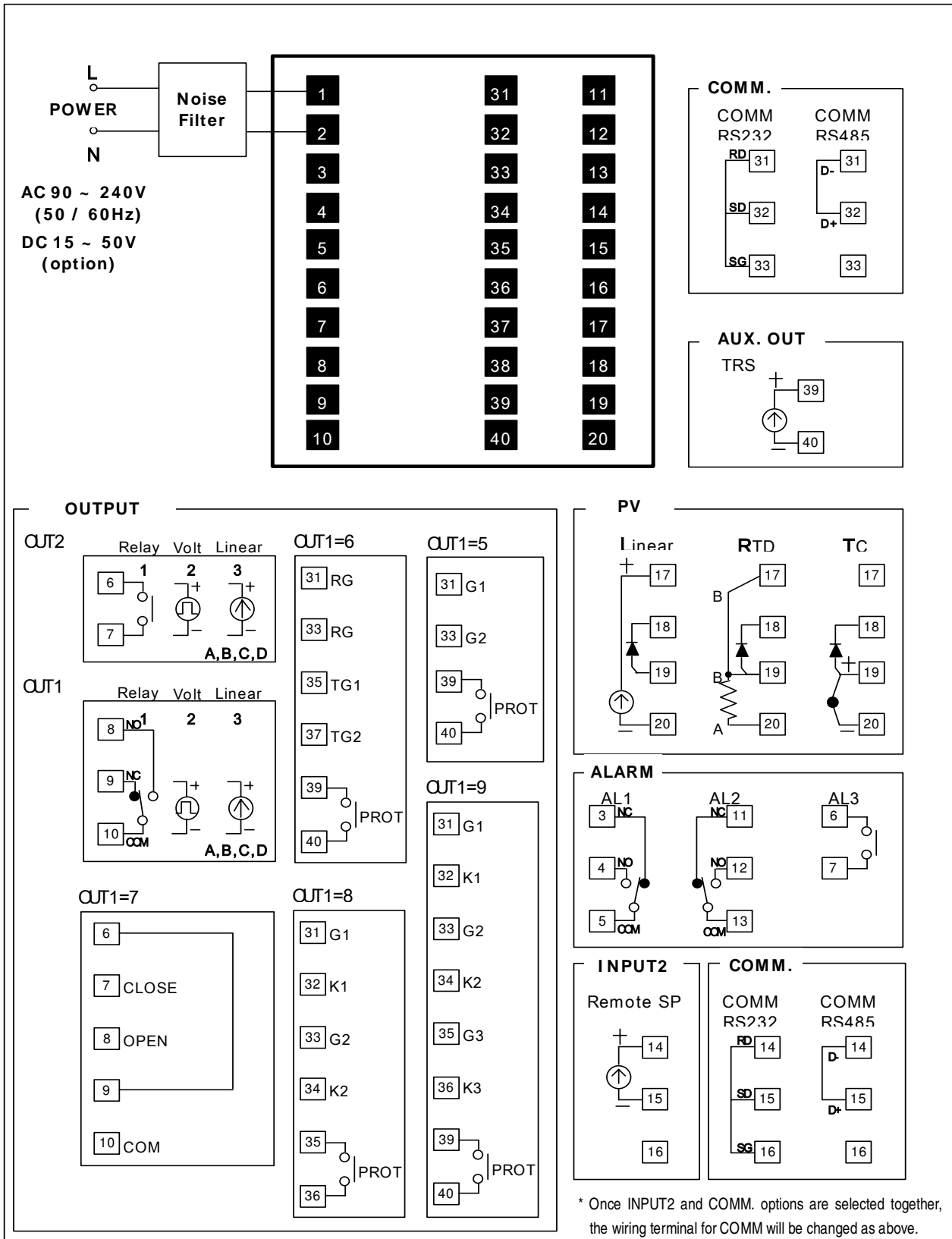

3. Configuration

3.1 Operator Interface

Upper Display	4 digits dedicated to display the PV. In configuration mode, this display indicates the name of parameter.
Lower Display	4 digits dedicated to display the SP. In configuration mode, this display indicates the value of parameter or the status of parameter selected.
Bar Graph LEDs	A bargraph of 10 green LEDs' indicates the value of the output in percentage.
OUT1	Status of 'Output 1'.
OUT2	Status of 'Output 2'.
AT	When the LED is ON, it indicates the controller is in automatic tuning process .
AL1	Status of 'Alarm 1'.
AL2	Status of 'Alarm 2'.
AL3	Status of 'Alarm 3'.
MAN	When the LED is ON, it indicates the controller is in manual mode.
PRO	When a program is running, the LED flickers. When a program is suspended, the LED is ON. When no program is running, the LED is OFF.
Keys	
SET	SET key allows moving from one parameter to another or saving a new value of parameter or a status of parameter changed.
A/M	A/M key allows switching from automatic mode to manual mode or from manual mode to automatic mode.
SHIFT	SHIFT key allows shifting the digits to modify parameters.
UP	UP key allows increasing the value of a digit selected or changing the status of parameter.
DOWN	DOWN key allows decreasing the value of a digit selected or changing the status of parameter.

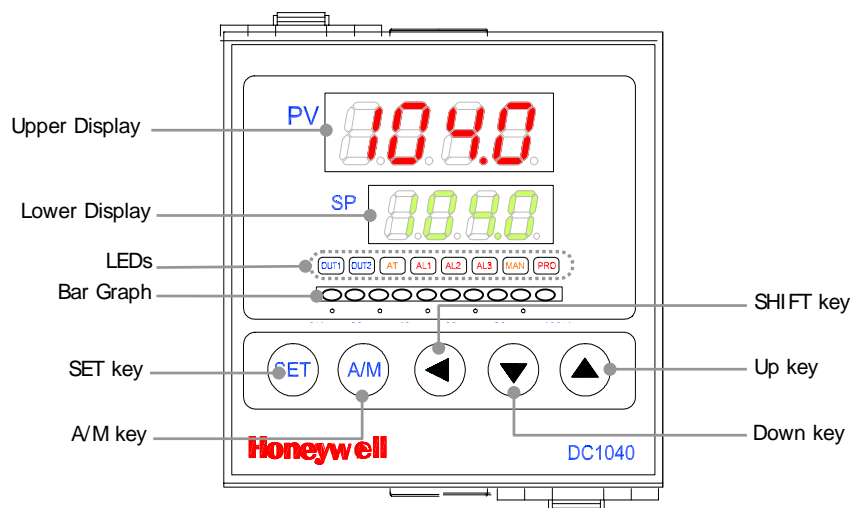

3.2 MODE Access

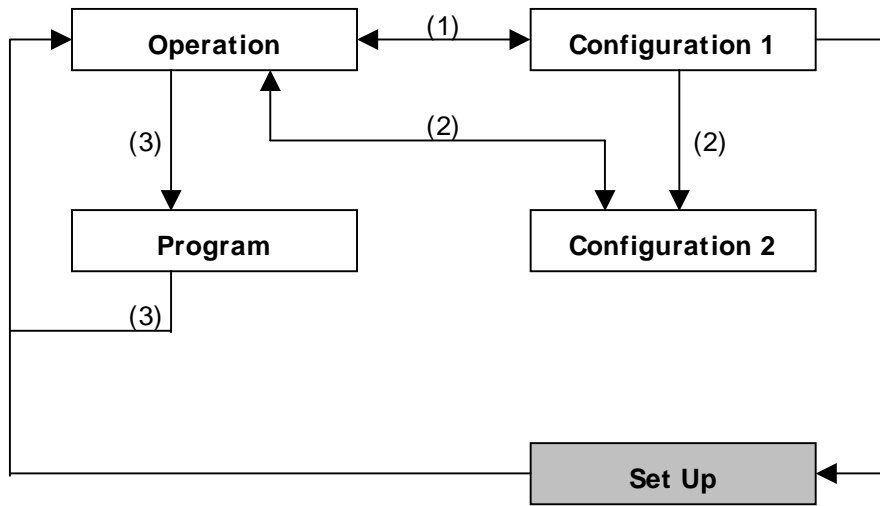

How to move from one MODE to another













- (1) Press 'SET' key for 5 seconds; it grants access to 'Configuration 1' mode or return to 'Operation' mode from 'Configuration 1' mode.
- (2) Press 'SHIFT' key for 5 seconds while pressing 'SET' key first; it grants access to 'Configuration 2' mode or return to 'Operation' mode.
- (3) All parameters related to program configuration will be displayed next to parameters in 'Operation' mode. (* These parameters will be shown in program model only)

NOTICE

DO NOT access 'Set Up' mode without instruction from technical assistant.

3.3 MODEs

3.3.1 Operation

	Parameter	Description
	PV Display	
	SP Display	
↓ SET		
	Output Limit	To limit the Maximum of Control Ouput
	Percentage (%)	
↓ SET		
	Auto Tuning	
	Status	* Default 'No'
↓ SET		
	Alarm 1	Enter deviation value or absolute value
	Value of alarm setpoint	Depending on alarm mode selected
↓ SET		
	Alarm 2	
	The same with Alarm1	
↓ SET		
	Alarm 3	
	The same with Alarm 1	

* The 'OUTL' is not shown in default mode.

* 'AL2' & 'AL3' are shown only in the model the relevant options are taken.

3.3.2 Configuration 1

'Configuration 1' will be shown by pressing 'SET' key for 5 seconds in 'Operation' mode.

	Parameter	Description
	Main Control (OUT1) P value (Proportional Band)	Range: 0~200% P1=0, ON/OFF Control
↓ SET		
	Main Control (OUT1) I value (Integral Time)	Range: 0~3600 seconds I=0, Integral off
↓ SET		
	Main Control (OUT1) D value (Derivative Time)	Range: 0~900 seconds D=0, Derivative off
↓ SET		
	Main Control Dead-Band Time	* DO NOT CHANGE THE VALUE
↓ SET		
	Main Control (OUT1) 'Auto tuning' offset	Range: 0~ Upper limit value (USPL) Prevent from 'Overshoot' during auto tuning
↓ SET		
	Main Control (OUT1) Cycle of Control Output	Output type (SSR → 1, 4~20mA→0, relay→10) Range: 0~150 seconds
↓ SET		
	Main Control (OUT1) Actuation of Hysteresis	Just in case of ON/OFF control (P1=0) (Range: 0~1000) ON : $PV < (SP - HYS1)$ OFF : $PV > (SP + HYS1)$
↓ SET		
	Sub Control (OUT2) P value (Proportional band)	The same with the method of P1 configuration
↓ SET		
	Sub Control (OUT2) I value (Integral Time)	The same with the method of I1 configuration
↓ SET		
	Sub Control (OUT2) D value (Derivative Time)	The same with the method of D1 configuration
↓ SET		
	Sub Control (OUT2) Cycle of Control Output	The same with the method of CYT1 configuration
↓ SET		
	Sub Control (OUT2) Hysteresis	The same with the method of HYS1 configuration
↓ SET		
	Main Control (OUT 1) Gap	Control output is turned off before getting to SP Turning Point = $SP - GAP1$; OFF (OUT1=Heat)
↓ SET		
	Sub Control (OUT2) Gap	Control Output to be turned on before getting to SP Turning Point = $SP + GAP2$; ON (OUT2=Cool)
↓ SET		
	Function Lock	* Refer to '2.3 Function Lock' in P.10
↓ SET		

* The parameters are only for 'Output' 2 function, so it will appear only in the model which has the "OUT2" option.

3.3.3 Configuration 2

'Configuration 2' mode will be shown by pressing 'SHIFT' key for 5 seconds WHILE pressing 'SET' key FIRST in 'Operation' or 'Configuration 2' mode.

	Parameter	Description
	Input 1 (INP1)	To define input type & input range * Refer to
↓ SET		
	Input 1 (INP1) Lower limit of linear Input	To be used during the calibration for linear input * DO NOT change this value without technical support
↓ SET		
	Input 1 (INP1) Upper limit of linear Input	To be used during the calibration for linear input * DO NOT change this value without technical support
↓ SET		
	Decimal Point	Available in linear input only
↓ SET		
	Lower limit of Input range	i.e) Linear input = 4~20mA, when 4mA (0%), set the indication value for lower limit
↓ SET		
	Upper limit of Input range	when 20mA (100%), set the indication value for upper limit
↓ SET		
	Input 2 (INP2) Lower limit of linear input	To be used during the calibration for linear input * DO NOT change this value without technical support
↓ SET		
	Input 2 (INP2) Upper limit of linear input	To be used during the calibration for linear input * DO NOT change this value without technical support
↓ SET		
	Alarm Code of 'Alarm 1'	* Refer to
↓ SET		
	Time Set for 'Alarm 1'	* Range: 0 - 99 min 59 sec 0= flickering alarm, 99.59= continuant alarm Others = Time delav of alarm
↓ SET		
	Alarm Code of 'Alarm2'	
↓ SET		
	Time Set for 'Alarm 2'	The same configuration method with ALT1
↓ SET		
	Alarm Code of 'Alarm 3'	
↓ SET		
	Time Set for 'Alarm 3'	The same configuration method with ALT1
↓ SET		
	Hysteresis of alarms	To set the hysteresis of alarm actuation (Range: 0 – 1000) ON : $PV \leq (SP - HYS1)$ OFF : $PV > (SP + HYS1)$
↓ SET		

	Parameter	Description
	Main Control (OUT1) Lower limit of linear output	To adjust the linear control output during the calibration * DO NOT change the value without technical support
	Main Control (OUT1) Upper limit of linear output	To adjust the linear control output during calibration * DO NOT change the value without technical support
	Sub Control (OUT2) Lower limit of linear output	The same configuration method with 'CL01'
	Sub Control (OUT2) Upper limit of linear output	The same configuration method with 'CH01'
	Aux. Output Lower limit of linear output	The same configuration method with 'CL01'
	Aux. Output Upper limit of linear output	The same configuration method with 'CH01'
	Timer for Motor Control	Full actuation time of Time proportional motor control Range: 5 – 200 sec
	WAIT function	To set 'wait' for program operation 0= No wait, others = Wait volume
	Extra SET	DO NOT change the value of this parameter
	ID Number	Communication ID number
	Baud Rate	DO NOT change the value of this parameter
	SP compensation	Range: -1000~1000
	PV compensation	Range: LSPL~ USPL
	Unit of PV & SP	Selection: C, F, and A (linear)
	Soft Filter	To adjust PV response time (Range: 0.05 – 1.00) * The bigger value gives the faster response.

* Those 2 parameters are only for adjusting the linear signal of control output, not for the limitation of the control output or any other purpose. Please, DO NOT change the values without Technical Support, see Contacts page.



Parameter	Description
CASC	* DO NOT change the value
QUD HEAL	Operation Mode Heating (direct) or Cooling (reverse)
DPA/F SF=Y	Control Process PID or Fuzzy
H= 60	Frequency 50 or 60Hz * Please, check whether the proper frequency is selected

3.4 Alarms

3.4.1 Deviation Alarm

The Alarm SP (Set Point) is to be changed as the SP moves. In this case, the Alarm SP preserves a certain deviation value with the SP. When an alarm is set, a certain deviation value with the preset SP should be defined.

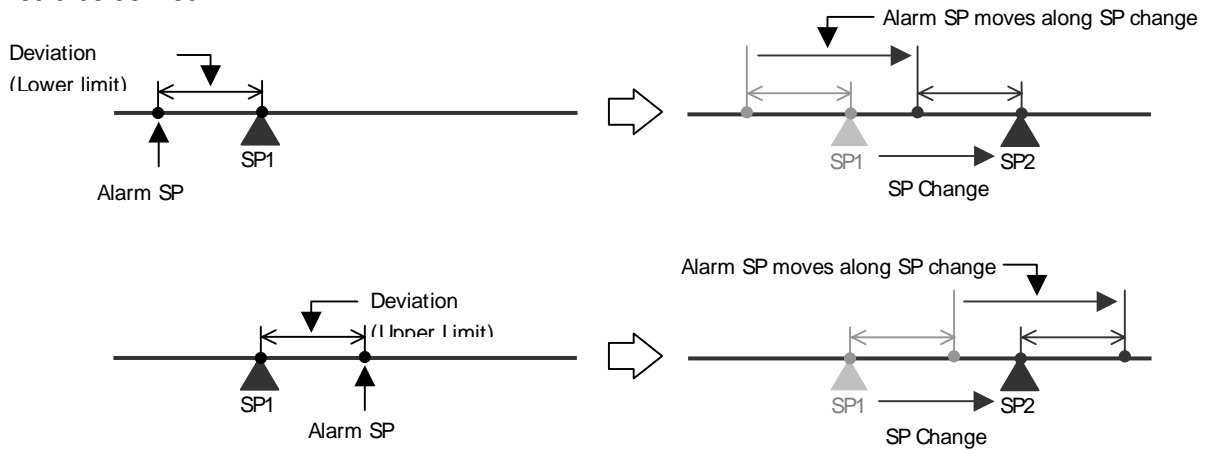

3.4.1.1 Upper Limit Deviation Alarm (Alarm Code 01, Alarm release in the first alarming situation)

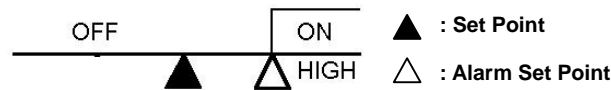

3.4.1.2 Upper Limit Deviation Alarm (Alarm Code 11, No alarm release in the first alarming situation)



3.4.1.3 Lower Limit Deviation Alarm (Alarm Code 02, Alarm release in the first alarming situation)



3.4.1.4 Lower Limit Deviation Alarm (Alarm Code 12, No alarm release in the first alarming situation)



3.4.1.5 Dev. Band Breakaway Alarm (Alarm Code 03, Alarm release in the first alarming situation)

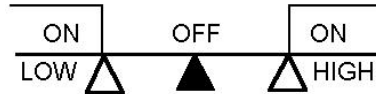

3.4.1.6 Dev. Band Breakaway Alarm (Alarm Code 13, No alarm release in the first alarming situation)



3.4.1.7 Deviation Band Alarm (Alarm Code 04, Alarm release in the first alarming situation)

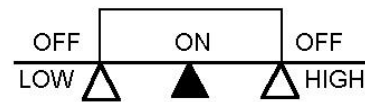

3.4.1.8 Deviation Band Alarm (Alarm Code 14, No alarm release in the first alarming situation)

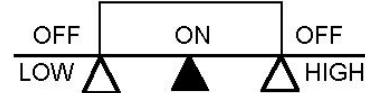

3.4.2 Absolute Value Alarm

The Alarm SP (Set Point) is to be fixed even though the SP moves. When an alarm is set, the absolute value of the Alarm SP should be defined.

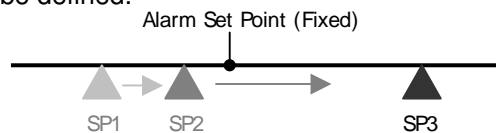

3.4.2.1 Absolute Upper Limit Alarm (Alarm Code 05, Alarm release in the first alarming situation)

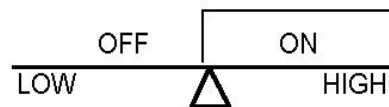

3.4.2.2 Absolute Upper Limit Alarm (Alarm Code 15, No alarm release in the first alarming situation)

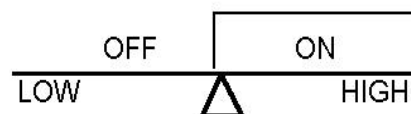

3.4.2.3 Absolute Lower Limit Alarm (Alarm Code 06, Alarm release in the first alarming situation)

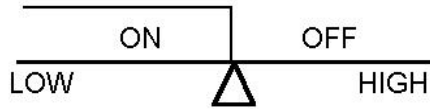

3.4.2.4 Absolute Lower Limit Alarm (Alarm Code 16, No alarm release in the first alarming situation)

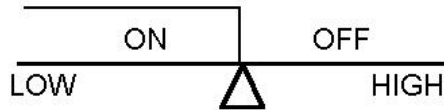

3.4.3 Program Alarm

3.4.3.1 Segment End Alarm (Alarm Code 07)

Once the selected segment is completed, the alarm becomes actuated

- ALD1 – ALD3 Set the Alarm Code 07
- AL1 – AL3 Enter Segment No. for alarms
- ALT1 – ALT3 Define the alarm timing
(0 → Flickering, 99.59 → Continuant, Others → Time Delay)

3.4.3.2 Program RUN Alarm (Alarm Code 17)

While a program runs, the alarm becomes actuated

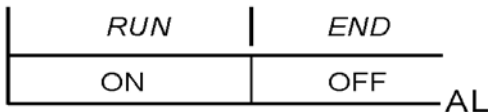

3.4.4 System Alarm

3.4.4.1 System Error Alarm (Alarm Code 08)



3.4.4.2 System Error Alarm (Alarm Code 18)

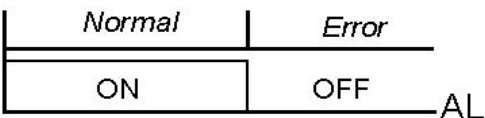

3.4.4.3 Timer Alarm (Alarm Code 19)

Once the PV reaches to the SP, the alarm becomes actuated after a certain time delay.
(Range: 00 hour 00 min – 99 hour 59 min)

3.5 Function Lock

According to the status of the parameter “LCK” in ‘Configuration 1’ mode, ‘access to modes’ and ‘change of values’ can be prohibited.

LCK=0000	MODE ACCESS	Access to ‘Operation’, ‘Configuration1 & 2’ modes allowe (* Default)
LCK=0100	MODE ACCESS	Access to ‘Operation’ & ‘Configuration 1’ mode allowed
	VALUE CHANGE	Every value change in each mode allowed
LCK=0110	MODE ACCESS	Access to ‘Operation’ & ‘Configuration 1’ mode allowed
	VALUE CHANGE	Value changes only in ‘Operation’ mode allowed
LCK=0001	MODE ACCESS	Access to ‘Operation’ mode allowed
	VALUE CHANGE	Value change of SP (Set Point) allowed only
LCK=1111	MODE ACCESS	Access to “Set Up” mode allowed
LCK=0101		All access & value changes prohibited except the change of “LCK” status



WARNING

PERSONAL INJURY:

Configuration should be performed only by personnel who are technically competent to do so. Local Regulations regarding electrical & safety must be observed.

Failure to comply with these instructions could result in death or serious injury.

4. Input Codes

The input code in 'Configuration 2' mode must be selected properly before the operation starts.

4.1 Thermocouples

TYPE	CODE	RANGE	
K	K1	0.0~200.0°C	0.0~392.0°F
	K2	0.0~400.0°C	0.0~752.0°F
	K3	0~600°C	0~1112°F
	K4	0~800°C	0~1472°F
	K5	0~1000°C	0~1832°F
	K6	0~1200°C	0~2192°F
J	J1	0.0~200.0°C	0.0~392.0°F
	J2	0.0~400.0°C	0.0~752.0°F
	J3	0~600°C	0~1112°F
	J4	0~800°C	0~1472°F
	J5	0~1000°C	0~1832°F
	J6	0~1200°C	0~2192°F
R	R1	0~1600°C	0~2912°F
	R2	0~1796°C	0~3216°F
S	S1	0~1600°C	0~2912°F
	S2	0~1796°C	0~3216°F
B	B1	0~1820°C	0~3308°F
E	E1	0~800°C	0~1472°F
	E2	0~1000°C	0~1832°F
N	N1	0~1200°C	0~2192°F
	N2	0~1300°C	0~2372°F
T	T1	0.0~400.0°C	0.0~752.0°F
	T2	0.0~200.0°C	0.0~392.0°F
	T3	0.0~350.0°C	0.0~662.0°F
W	W1	0~2000°C	0~3632°F
	W2	0~2320°C	0~2372°F
PLI	PL1	0~1300°C	0~2372°F
	PL2	0~1390°C	0~2534°F
U	U1	-199.9~600.0°C	-199.9~999.9°F
	U2	-199.9~200.0°C	-199.9~392.0°F
	U3	0.0~400.0°C	0.0~752.0°F
L	L1	0~400°C	0~752°F
	L2	0~800°C	0~1472°F

* The default of Input Code is 'K2' for the model of thermocouple input type. (DC10X0XT-XXX-XXX-X)

4.2 RTDs

TYPE	CODE	RANGE	
JIS Pt100	JP1	-199.9~600.0°C	-199.9~999.9°F
	JP2	-199.9~400.0°C	-199.9~752.0°F
	JP3	-199.9~200.0°C	-199.9~392.0°F
	JP4	0~200°C	0~392°F
	JP5	0~400°C	0~752°F
	JP6	0~600°C	0~1112°F
DIN Pt100	DP1	-199.9~600.0°C	-199.9~999.9°F
	DP2	-199.9~400.0°C	-199.9~752.0°F
	DP3	-199.9~200.0°C	-199.9~392.0°F
	DP4	0~200°C	0~392°F
	DP5	0~400°C	0~752°F
	DP6	0~600°C	0~1112°F
JIS Pt50	JP1	-199.9~600.0°C	-199.9~999.9°F
	JP2	-199.9~400.0°C	-199.9~752.0°F
	JP3	-199.9~200.0°C	-199.9~392.0°F
	JP4	0~200°C	0~392°F
	JP5	0~400°C	0~752°F
	JP6	0~600°C	0~1112°F

* The default of Input Code is 'DP3' for the model of RTD input type. (DC10X0XR-XXX-XXX-X)

4.3 Linear Inputs

CODE	SIGNAL	INPUT TYPE	RANGE
AN1	-10 - 10mV		-1999~9999
AN2	0 - 10mV		-1999~9999
AN3	0 - 20mV		-1999~9999
AN4	0 - 50mV	0-20mA, 0-1V, 0-5V, 0-10V	-1999~9999
AN5	10 - 50mV	4-20mA, 1-5V, 2-10V	-1999~9999

* The default of Input Code is 'AN5' (4-20mA) for the model of linear input type.

(DC10X0XL-XXX-XXX-X)

NOTICE

* DO NOT change the input type without Technical Support because some hardware changes are required on the input board in order to select a certain linear input type.

5. Operation

5.1 Type of Control

5.1.1 Manual Operation

The control output can be managed manually. When the 'A/M' key is pressed, the parameter of 'OUTL' will appear in the upper display, and a fixed control output is shown in lower display (% value). Once the value is changed, the control output is changed and fixed again.

5.1.2 ON/OFF Control

The output type must be Relay Output (DC10X0XX-1XX-XXX-X). The 'P' value can be changed to 0 in 'Configuration 1' mode to produce an ON/OFF control output.

When the PV (process variable) reaches the SP (set point), the control output is ON (100%), when it reaches the SP the control output becomes OFF (0%).

* To prevent the control output from flickering too frequently the hysteresis ('HYS1' in 'Operation' mode) is to be set.

5.1.3 PID Control

PID control is the default control type of this controller. If 'AT' in 'Operation' mode becomes 'YES', the auto tuning process will start. After the auto tuning is completed, the controller gets optimum PID values for the control system and starts the operation automatically. (PID values can be set manually in 'Configuration 1' mode without auto tuning procedure.)

5.2 Set Point

After all the wiring connection is completed and power is applied, the targeted SP (Set Point) is to be entered. When power is applied, the default display is the PV & SP display. The SP may now be entered. (Change the value targeted, and press 'SET' key for saving)

5.3 Alarm Set Point

If necessary, each alarm should be set properly.

- Set the Alarm Code required in 'ALd1' (ALd2 / ALd3) in 'Configuration 2' mode
(Alarm Code: 00 to 19)
- Define the alarm timing required for 'ALt1' (ALt2 / ALt3) in 'Configuration 2' mode
'0000' → flickering alarm, '9959' → continuant alarm
'XXXX' → XX min XX sec (Time Delay)
- Enter the deviation value or absolute value in 'AL1' (AL2 / AL3) in 'Operation' mode depending on the Alarm Code selected above.
- Set the hysteresis of alarms in 'HYS1' in 'Configuration 2' mode. (If necessary)

6. Error Message

In case the following error messages appear in the upper display of controller, please refer to the Error message table below, or call technical support. See Contacts page for details.

Sign	Description	Solution
1 n IE	Open the circuit of 'INPUT 1' (sensor)	Check the wiring
* AdCF	A/D Convert Failure	Service Call required
* CJCE	Cold junction compensation failure	Service Call required
1 n 2E	Open the circuit of 'INPUT 2' (sensor)	Check the wiring
UUU 1	Excess of PV over upper limit (INPUT 1)	- Check sensor wiring & input code - Adjust the range of indication
nnn 1	Shortage of PV under lower limit (INPUT1)	
UUU 2	Excess of PV over upper limit (INPUT2)	
nnn 2	Shortage of PV under lower limit (INPUT2)	
* r AdF	Memory (RAM) failure	Service call required
1 n tF	Interface failure	Check wiring of input
AU tF	Auto tuning failure	Check wiring of output



WARNING

PERSONAL INJURY:

Controller checks should be performed only by personnel who are technically competent to do so. Local Regulations regarding electrical & safety must be observed.

Failure to comply with these instructions could result in death or serious injury.



Sales and Service

For application assistance, current specifications, pricing, or name of the nearest Authorized Distributor, contact one of the offices below.

Warranty/Remedy

Honeywell warrants goods of its manufacture as being free of defective materials and faulty workmanship. Contact your local sales office for warranty information. If warranted goods are returned to Honeywell during the period of coverage, Honeywell will repair or replace without charge those items it finds defective. **The foregoing is Buyer's sole remedy and is in lieu of all other warranties, expressed or implied, including those of merchantability and fitness for a particular purpose.** Specifications may change without notice. The information we supply is believed to be accurate and reliable as of printing. However, we assume no responsibility for its use. While we provide application assistance personally, through our literature and the Honeywell website, it is up to the customer to determine the suitability of the product in the application. © Copyright 2004. Honeywell International Inc. All rights reserved.

ASIA PACIFIC

Australia

Honeywell Limited
Phone: +(61) 2-9370-4500
FAX: +(61) 2-9370-4525

Beijing

Honeywell (Tianjin) Ltd
Phone: +(86-10) 8458-3280
Fax: +(86-10) 8458-3103

Shanghai

Honeywell (Tianjin) Ltd
Phone: (86-21) 6237-0237
Fax: (86-21) 6237-0775

Hong Kong S.A.R.

Honeywell Ltd.
Phone: +(852) 2953-6412
Fax: +(852) 2953-6767

Chengdu

Honeywell China Inc.
Phone: +(86-28) 8678-6348
Fax: +(86-28) 8678-7061

Guangzhou

Honeywell China Inc.
Phone: +(86-20) 3879-1169
Fax: +(86-20) 3879-1269

Shenzhen

Honeywell China Inc.
Phone: +(86) 755-2518-1226
Fax: +(86) 755-2518-1221

Indonesia

PT Honeywell Indonesia
Phone: +(62) 21-535-8833
FAX: +(62) 21-536-71008

India

TATA Honeywell Ltd.
Phone: +(91) 20 687 0445/0446
Fax: +(91) 20 681 2243/687 5992

Japan

Honeywell Inc
Phone: +(81) 3 5440 1425
Fax: +(81) 3 5440 1368

South Korea

Honeywell Co., Ltd
Phone: +(82) 2 799-6146
Fax: +(82) 2 792-9013

Malaysia

Honeywell Engineering Sdn Bhd
Phone: +(60-3) 7958-4988
Fax: +(60-3) 7958-8922

New Zealand

Honeywell Limited
Phone: +(64-9) 623-5050
Fax: +(64-9) 623-5060

Philippines

Honeywell Systems (Philippines) Inc.
Phone: +(63-2) 633-2830
Fax: +(63-2) 638-4013

Singapore

Honeywell Pte Ltd
Phone: +(65) 6355-2828
Fax: +(65) 6445-3033

Thailand

Honeywell Systems (Thailand) Ltd.
Phone: +(662) 693-3099
FAX: +(662) 693-3085

Taiwan R.O.C.

Honeywell Taiwan Ltd.
Phone: +(886-2) 2245-1000
FAX: +(886-2) 2245-3242

LATIN AMERICA

Argentina

Honeywell S.A.I.C.
Phone: +(54-11) 4383-3637
FAX: +(54-11) 4325-6470

Brazil

Honeywell do Brasil & Cia
Phone: +(55-11) 7266-1900
FAX: +(55-11) 7266-1905

Chile

Honeywell Chile, S.A.
Phone: +(56-2) 233-0688
FAX: +(56-2) 231-6679

Mexico

Honeywell S.A. de C.V.
Phone: +(52) 55 5259-1966
FAX: +(52) 55 5570-2985

Puerto Rico

Honeywell Inc.
Phone: +(809) 792-7075
FAX: +(809) 792-0053

Trinidad

Honeywell Inc
Phone: +(868) 624-3964
FAX: +(868) 624-3969

Venezuela

Honeywell CA
Phone: +(58-2) 238-0211
FAX: +(58-2) 238-3391

NORTH AMERICA

Canada

Honeywell LTD
Phone: 1-800-737-3360
FAX: 1-800-565-4130

USA

Honeywell Control Products, International Headquarters
Phone: 1-800-537-6945
1-815-235-6847
FAX: 1-815-235-6545
E-mail: info.sc@honeywell.com

EUROPE

Austria

Honeywell Austria Ges.m.b.H.
Phone: +43 (1) 727 80 - 0
Fax: +43 (1) 727 80 - 8

Balkan Countries

Please contact the Honeywell Italian office

Belgium

Honeywell SA/NV
Phone: +32(0)27282776
FAX: +32(0)27282329

Bulgaria

Honeywell EOOD
Phone: +359 29790017 & ext /18 /23 /26
FAX: +35-929 790024 & +359 29713213

Czech Republic

Honeywell spol. s.r.o.
Phone: +420 242442205
FAX: +420 242442131

Denmark

Honeywell A/S
Phone: +(45) 39 55 55 55
FAX: +(45) 39 55 55 58

Finland

Honeywell OY
Phone: +358 (3) 2727625
FAX: +358 (3) 2728600

France

Honeywell SA
Phone: +33 (0)1 60198075
FAX: +33 (0)1 60198201

Germany

Honeywell GmbH
Phone: +49 (69)8064299
FAX: +49 (69)8064931

Hungary

Honeywell Kft.
Phone: +36-1-451 4335
FAX: +36-1-451 4343

Italy

Honeywell S.p.A.
Phone: +39 02 9214 6347
FAX: +39 0292146377

The Netherlands

Honeywell B.V.
Phone: +31(0)205656200
FAX: +31(0)205656210

Norway

Honeywell A/S
Phone: +47 66762000
FAX: +47 66762090

Poland

Honeywell Sp. zo.o
Phone: +48-22-6060900
FAX: +48-22-6060901

Portugal

Honeywell Portugal S.A.
Phone: +351 21 424 5000
FAX: +351 21 424 50 99

Romania

Honeywell Bucharest
Phone: 0040212316437 & 0040212316438
FAX: 0040212316439

Russia and (CIS)

Z.A.O. Honeywell, Moscow
Phone: +(7 095) 796 98 00/81
FAX: +(7 095) 796 98 93/94

Slovak Republic

Honeywell s.r.o.
Phone: +421-2-58247 400
FAX: +421-2-58247 415

Spain

Honeywell S.A.
Phone: +34 (0)91313 61 00
FAX: +34 (0)91313 62 78

Sweden

Honeywell AB
Phone: +(46) 8 775 55 00
FAX: +(46) 8 775 56 00

Switzerland

Honeywell AG
Phone: +41 (1) 855 24 24
FAX: +41 (1) 855 24 25

Turkey

Honeywell Turkey A.S.
Phone: +90 216 575 6600
FAX: +90 216 575 6637

United Kingdom

Honeywell Control Systems Ltd
Phone: +(44) 1344 655251
FAX: +(44) 1344 655554

Ukraine

Honeywell
Phone: 38-044 201 4474
Fax: 38-044 201 4475

AFRICA

South Africa (Republic of)

Honeywell Southern Africa
Honeywell S.A. Pty. Ltd
Phone: +27 11 6958000
FAX +27 118051504

English Speaking Africa

Please contact the Honeywell South African office.

French Speaking Africa

Please contact the Honeywell French office in EUROPE

MIDDLE EAST

Abu Dhabi U A E

Middle East Headquarters
Honeywell Middle East Ltd
Phone: +971 24432119
FAX: +971 24432536

Sultanate of Oman

Honeywell & Co Oman LLC
Phone: +968 701397
FAX +968 787351

Egypt

Honeywell Egypt Ltd
Phone: +202 6905516 & ext. /17 /18 /19
FAX : +202 6905523

Saudia Arabia

Honeywell Turki Arabia Limited
Phone: +966-3-341-0140
Fax: +966-3-341-0216

Kuwait

Honeywell Kuwait KSC
Phone: +965 2421327
Fax: +965 2428315

Qatar

Honeywell Middle East
Phone: 974-4837768/9
Fax: 974-4837765

Honeywell

Industrial Measurement & Controls

Honeywell Korea
191 HanGangRo 2ga YongSanGu
Seoul, Korea