

CDS2000A SERIES



CO₂ GAS DETECTOR

PRODUCT SPECIFICATION SHEET



CDS2000A1000C



CDS2000A2000C

APPLICATION

CDS2000A series is CO₂ gas detector for use IAQ(Indoor Air Quality) applications, which is designed to detect carbon dioxide gas in the air.

This model has good resolution by NDIR method, so it is a optimum device for ventilation of building, house, etc.

Also, the advantage of this model is compact size and easy installation.

Note. Do not apply this product for use where a building is continuously occupied 24 hours per day.

FEATURES

- High sensitivity and good resolution
- High technology adopted by NDIR method
- LCD display model available
- On/off relay output for CO₂ limit monitoring
- Two types of analog signal(DCV and DCA) output
- Easy installation
- Compact size (70mm×122mm×32mm)
- CE Approval
- Low power consumption
- Eliminates the need for calibration in most applications with ABC logic software.

Contents

Application	1
Features	1
Specification	1~2
Dimensions	2
Installation	2
Assembly	2
Wiring Diagram	3
Cautions on Use.....	4

SPECIFICATION

Model	Display	Analog output	Alarm output
CDS2000A1000C	None	0 ~ 10Vdc, 0~20mAdc	None
CDS2000A2000C	LCD display	0 ~ 10Vdc, 0~20mAdc	Relay contact

Gas detected	: Carbon dioxide (CO ₂)
Sensing method	: NDIR(Non-dispersive infrared)
Detect range	: 0~2,000ppm
Accuracy	: ± 30ppm ± 5% of reading
Power consumption	: 2W max.
Power supply	: 24Vac, 24Vdc ± 20%, 50/60Hz
Sensor life	: greater than 10 years
Maintenance interval	: not required
Analog output	: 0~10Vdc(default) or 0~20mA (selectable by jumper setting)
Alarm output	: SPST relay, normally open, 1A/120Vac, 1A/24Vdc contact rating, activated at greater than 1000ppM, deactivated at less than 900ppM
Coverage area	: approximately 100 m ²
Response time	: Within 120 sec (90% step)
Protection class	: IP30
Operating conditions.	: 0 ~ 50 °C : 0 ~ 95%RH (non condensing)
Storage conditions	: -20 ~ 60 °C : 0 ~ 95%RH (non condensing)

→Voltage output (0~10Vdc): set Jumper(JPI) on the top of PCB to "V-OUT" position (refer to the output selection method figure)

→Current output (0~20mA): set jumper (JPI) on the top of PCB to "I-OUT" position (refer to the output selection method figure)

3. Installation procedure

- ① Connect power and signal output wires to the terminal block at the back side of device. Then, verify the lines correctly fixed to the terminal (refer to the wiring method figure & assembly figure)
- ② Push the bottom of front cover to separate from the base (refer to the assembly figure)
- ③ Make sure to distinguish the upper and lower sides of the base and fix the base with screw nails (be cautious PCB assembly not to be damaged)
- ④ Reassemble the cover.

4. Recommended installation location

- ① Mount approximately 120~180cm above the floor
- ② Avoid the following places to install
 - A place within 1m from the gate or window
 - A place near a ventilation system in which in directly affects the flow of the air
 - A place within 1m from the corner where two walls are attached
 - A place which is likely to be influenced by breath
- ③ If sudden movement of the device from cold place to warm place makes it dewy, make sure to dry it enough before using again.
- ④ When installing, power and output wires must keep enough distance with other utility power lines for safety

DIMENSIONS

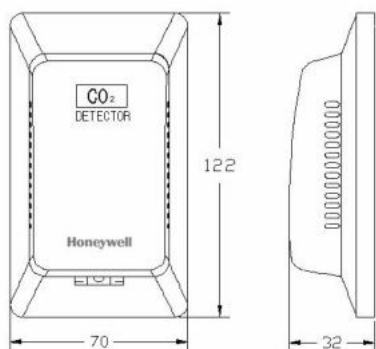

Fig. 1 dimensions (mm)

INSTALLATION

1. Confirm the product model number on the package box and check wiring method (refer to wiring method figure).
2. Analog output mode change
 - Initially, output mode is configured as 0~10Vdc

ASSEMBLY

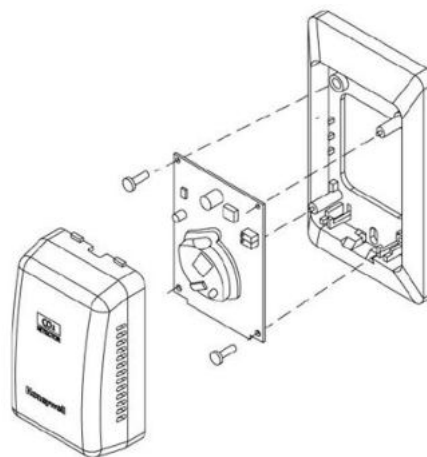
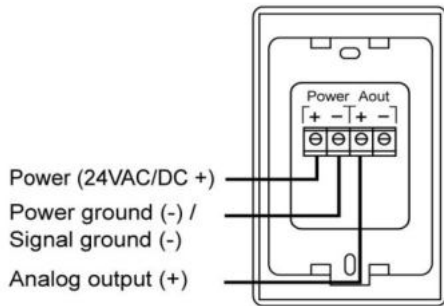

Fig. 2 assembly structure

WIRING DIAGRAM

3-line wiring



4-line wiring

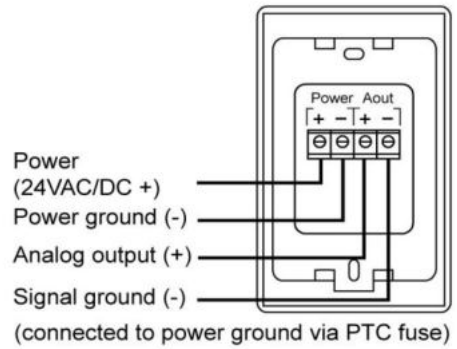
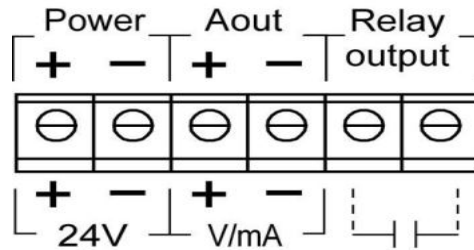
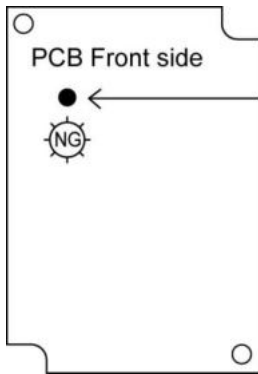

Fig. 3 wiring diagram

CDS2000A2000C wiring connection



Caution on wiring



AC24V wiring polarity error notice lamp

When power on, if this lamp lights, please change the AC24V power line polarity reversely.
 (The V/mA signal output is not electrically separated from AC 24V power line.)

ANALOG OUTPUT SELECTION

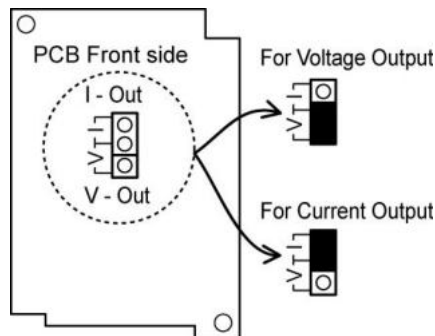

Fig. 4 analog output selection method (JP1)

CAUTIONS ON USE

- Do not use this device for outdoor use. This product is manufactured only for indoor use.
- Do not use this device for where a building is continuously occupied 24 hours per day, or where there could be significant sources of non-occupant related CO₂ such as greenhouses, breweries and other industrial and food processing applications.
- Do not use this device for medical, life or safety purpose.
- This device must abide by the operating temperature/humidity and the storage temperature/humidity.
- Do not leave or use the device for longtime in a highly damped place in which humidity is near 95%RH.
- The standard test condition in which the product was tested is 25°C±3°C, 50°C±30%RH. Signal may vary slightly by environment condition.
- Be careful when install and use as vibration/shock/falling can cause a serious damage on the sensor.
- We do not guarantee the performance of the device in case of user installation, disassembling and Inspection. When installing and inspection is necessary, please contact our technicians.
- Sensor using NDIR is influenced by air pressure. It can be used without correction within 300M above the sea level. However, add the output value by +1.0% per 100M height above 300M.
Ex) If the output signal is indicating 600ppm at the height of 500M, correct the output to 630ppm by adding 30(600*0.01*5)ppm.
- Use when it is fixed, but not use while it is in motion.

HONEYWELL

Honeywell Co., Ltd.

Environmental & Combustion Controls

5F, Sangam IT tower, DMC 1590 B4-4 block, Sangam-dong,

Mapo-gu, Seoul, 121-835, Korea

Tel. 82-2-799-6170/6074

Fax. 82-2-749-6119